



**TELEDYNE API**  
Everywhereyoulook™



**User Manual**  
***MODEL 470***  
***Dissolved Ozone Sensor***

© TELEDYNE API(TAPI)  
9970 CARROLL CANYON ROAD  
SAN DIEGO, CALIFORNIA 92131-1106  
USA

Toll-free Phone: 800-324-5190  
Phone: +1 858-657-9800  
Fax: +1 858-657-9816  
Email: [api-sales@teledyne.com](mailto:api-sales@teledyne.com)  
Website: <http://www.teledyne-api.com/>



## NOTICE OF COPYRIGHT

© 2018 Teledyne API. All rights reserved.

## TRADEMARKS

All trademarks, registered trademarks, brand names or product names appearing in this document are the property of their respective owners and are used herein for identification purposes only.

## SAFETY MESSAGES

Important safety messages are provided throughout this manual for the purpose of avoiding personal injury or instrument damage. Please read these messages carefully. Each safety message is associated with a safety alert symbol and is placed throughout this manual; the safety symbols are also located inside the instrument. It is imperative that you pay close attention to these messages, the descriptions of which are as follows:



WARNING: Electrical Shock Hazard



HAZARD: Strong oxidizer



GENERAL WARNING/CAUTION: Read the accompanying message for specific information.



CAUTION: Hot Surface Warning



Do Not Touch: Touching some parts of the instrument without protection or proper tools could result in damage to the part(s) and/or the instrument.



Technician Symbol: All operations marked with this symbol are to be performed by qualified maintenance personnel only.



Electrical Ground: This symbol inside the instrument marks the central safety grounding point for the instrument.

### CAUTION



This instrument should only be used for the purpose and in the manner described in this manual. If you use this instrument in a manner other than that for which it was intended, unpredictable behavior could ensue with possible hazardous consequences.

NEVER use any ozone analyzer to sample combustible fluid(s)!

For Technical Assistance regarding the use and maintenance of this instrument or any other Teledyne API product, contact Teledyne API's Technical Support Department:

Telephone: 800-324-5190

Email: [sda\\_techsupport@teledyne.com](mailto:sda_techsupport@teledyne.com)

or access any of the service options on our website at <http://www.teledyne-api.com/>

## CONSIGNES DE SÉCURITÉ

Des consignes de sécurité importantes sont fournies tout au long du présent manuel dans le but d'éviter des blessures corporelles ou d'endommager les instruments. Veuillez lire attentivement ces consignes. Chaque consigne de sécurité est représentée par un pictogramme d'alerte de sécurité; ces pictogrammes se retrouvent dans ce manuel et à l'intérieur des instruments. Les symboles correspondent aux consignes suivantes :



AVERTISSEMENT : Risque de choc électrique



DANGER : Oxydant puissant



AVERTISSEMENT GÉNÉRAL / MISE EN GARDE : Lire la consigne complémentaire pour des renseignements spécifiques



MISE EN GARDE : Surface chaude



Ne pas toucher : Toucher à certaines parties de l'instrument sans protection ou sans les outils appropriés pourrait entraîner des dommages aux pièces ou à l'instrument.



Pictogramme « technicien » : Toutes les opérations portant ce symbole doivent être effectuées uniquement par du personnel de maintenance qualifié.



Mise à la terre : Ce symbole à l'intérieur de l'instrument détermine le point central de la mise à la terre sécuritaire de l'instrument.

### MISE EN GARDE



Cet instrument doit être utilisé aux fins décrites et de la manière décrite dans ce manuel. Si vous utilisez cet instrument d'une autre manière que celle pour laquelle il a été prévu, l'instrument pourrait se comporter de façon imprévisible et entraîner des conséquences dangereuses.

**NE JAMAIS** utiliser un analyseur de gaz pour échantillonner des gaz combustibles!

## WARRANTY

### WARRANTY POLICY (02024J)

Teledyne API (TAPI), a business unit of Teledyne Instruments, Inc., provides that:

Prior to shipment, TAPI equipment is thoroughly inspected and tested. Should equipment failure occur, TAPI assures its customers that prompt service and support will be available. (For the instrument-specific warranty period, please refer to the “Limited Warranty” section in the Terms and Conditions of Sale on our website at the following link: [http://www.teledyne-api.com/terms\\_and\\_conditions.asp](http://www.teledyne-api.com/terms_and_conditions.asp)).

### COVERAGE

After the warranty period and throughout the equipment lifetime, TAPI stands ready to provide on-site or in-plant service at reasonable rates similar to those of other manufacturers in the industry. All maintenance and the first level of field troubleshooting are to be performed by the customer.

### NON-TAPI MANUFACTURED EQUIPMENT

Equipment provided but not manufactured by TAPI is warranted and will be repaired to the extent and according to the current terms and conditions of the respective equipment manufacturer’s warranty.

### PRODUCT RETURN

All units or components returned to Teledyne API should be properly packed for handling and returned freight prepaid to the nearest designated Service Center. After the repair, the equipment will be returned, freight prepaid.

The complete Terms and Conditions of Sale can be reviewed at [http://www.teledyne-api.com/terms\\_and\\_conditions.asp](http://www.teledyne-api.com/terms_and_conditions.asp)

#### CAUTION – Avoid Warranty Invalidation



Failure to comply with proper anti-Electro-Static Discharge (ESD) handling and packing instructions and Return Merchandise Authorization (RMA) procedures when returning parts for repair or calibration may void your warranty. For anti-ESD handling and packing instructions please refer to the manual, Fundamentals of ESD, PN 04786, in its “Packing Components for Return to Teledyne API’s Customer Service” section. The manual can be downloaded from our website at <http://www.teledyne-api.com>. RMA procedures can also be found on our website.

## TABLE OF CONTENTS

Safety Messages.....	ii
Warranty.....	iv
Table of Contents.....	v
List of Figures.....	v
List of Tables.....	v
<b>1. INTRODUCTION, SPECIFICATIONS, APPROVALS, &amp; COMPLIANCE.....</b>	<b>6</b>
1.1. Specifications.....	6
1.2. Safety.....	6
1.3. EMC.....	7
<b>2. GETTING STARTED.....</b>	<b>8</b>
2.1. Unpacking.....	8
2.2. Mechanical Installation.....	8
2.3. Pneumatic Connections.....	8
2.4. Electrical Connections.....	10
2.4.1. Power Supply.....	11
2.4.2. Analog Output.....	11
2.4.3. Zero Calibration Input.....	11
2.4.4. Status Outputs.....	12
2.4.5. RS232/485 Interface.....	12
<b>3. OPERATION.....</b>	<b>13</b>
3.1. Initial Power-on and Warm-up.....	13
3.2. Zeroing the Sensor.....	13
<b>4. TROUBLESHOOTING.....</b>	<b>14</b>
4.1. Status Output Summary.....	14
4.2. Status Output Descriptions.....	15
4.2.1. Sensor O.K.....	15
4.2.2. Invalid Reading.....	15
4.2.3. Lamp Low.....	15
4.2.4. Cell Dirty.....	15
<b>5. MAINTENANCE.....</b>	<b>16</b>
5.1. Technical Assistance.....	16

## LIST OF FIGURES

Figure 2-1. Sensor Diagram.....	8
Figure 2-2: In-Line, Full-Flow Configuration.....	9
Figure 2-3: Typical Installation, In-Line or Side-Stream.....	10
Figure 2-4: Digital Output Connections.....	11
Figure 2-5: Digital Status Outputs.....	12

## LIST OF TABLES

Table 1-1. Specifications.....	6
Table 4-1: Status Outputs.....	14
Table 4-2: Status Output Truth Table.....	14

## 1. INTRODUCTION, SPECIFICATIONS, APPROVALS, & COMPLIANCE

Teledyne API's Model 470 Dissolved Ozone Analyzer is designed for continuous measurement of dissolved ozone in deionized water with ranges up to 150 mg/l. Designed for semiconductor wet bench systems and many other industrial processes, the Model 470 sensor is "clean ready" for applications with high purity requirements. Its innovative dual optical-path sample sensing technology virtually eliminates the need for a reference fluid measurement.

The Model 470 operates from an external +15 VDC power source, and features a standard 0-5 volt, or 4-20 mA analog signal for reporting process concentration as well as 4 digital status outputs for sensor diagnostics. A bi-directional serial interface is also provided for computer control.

### 1.1. SPECIFICATIONS

Table 1-1 presents the instrument's specifications.

**Table 1-1. Specifications**

PARAMETER	SPECIFICATION
Measurement Range	50, 100, 150 mg/L
Units of Measure	mg/L
Precision	0.5 mg/L or 1% of reading (whichever is greater)
Repeatability	1% of Full Scale
Zero Drift	1% Full Scale/month (non-cumulative)
Response Time	2 seconds to 95%
Water Flow	Up to 150 SLPM
Power Input	+15 volts $\pm$ 1.0 volt (1.0A maximum)
Analog Output	0-5 VDC or 4-20 mA full scale
Serial Data	RS232 or RS485, Half-Duplex, 9600 Baud
Enclosure Material	PTFE Teflon®
Dimensions H x W x D (typical envelope)	6.75" x 5.69" x 3.2" (172 mm x 145 mm x 82 mm)
Temperature Range	5 - 40 °C
Humidity Range	0-95% RH non-condensing

### 1.2. SAFETY

IEC/EN 61010-1:2010 (3<sup>rd</sup> Edition), Safety requirements for electrical equipment for measurement, control, and laboratory use.

**CE:** [pending]



### 1.3. EMC

IEC/EN 61326-1, Class A Emissions/Industrial Immunity

EN55011 (CISPR 11), Group 1, Class A Emissions

FCC 47 CFR Part 15B, Class A Emissions

**CE:** [pending]

## 2. GETTING STARTED

This section addresses unpacking, connecting, and initializing the instrument.

### 2.1. UNPACKING

Upon receiving the Model 470 please verify that no apparent shipping damage has occurred. If damage has occurred please advise shipper first, then notify Teledyne API.

The sensor features two hydraulic ports, two pneumatic ports for purge gas, and one electrical 15-pin D-Sub connector at the end of a cable.

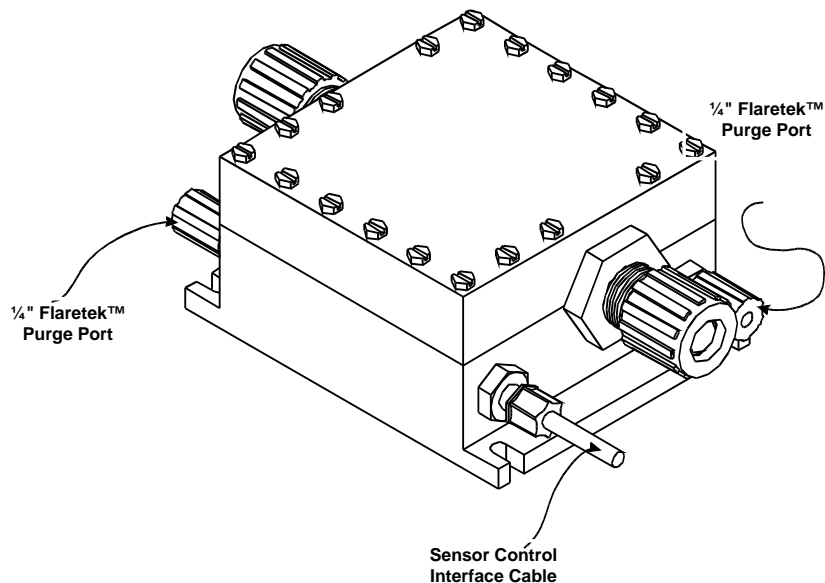

Figure 2-1. Sensor Diagram

### 2.2. MECHANICAL INSTALLATION

The sensor must be mounted vertically, with the ozonated solvent flowing upward. Use screws made of a material that is chemically compatible with the process being monitored.

Figure 2-1 in the next section shows the orientation.

### 2.3. PNEUMATIC CONNECTIONS



#### CAUTION

Liquid flow should be as indicated by the flow direction of the arrow on the sensor housing.

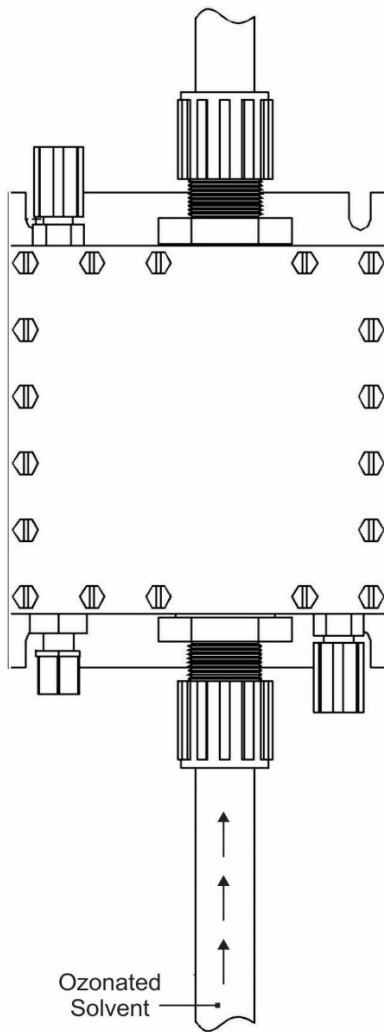

**Figure 2-2: In-Line, Full-Flow Configuration**

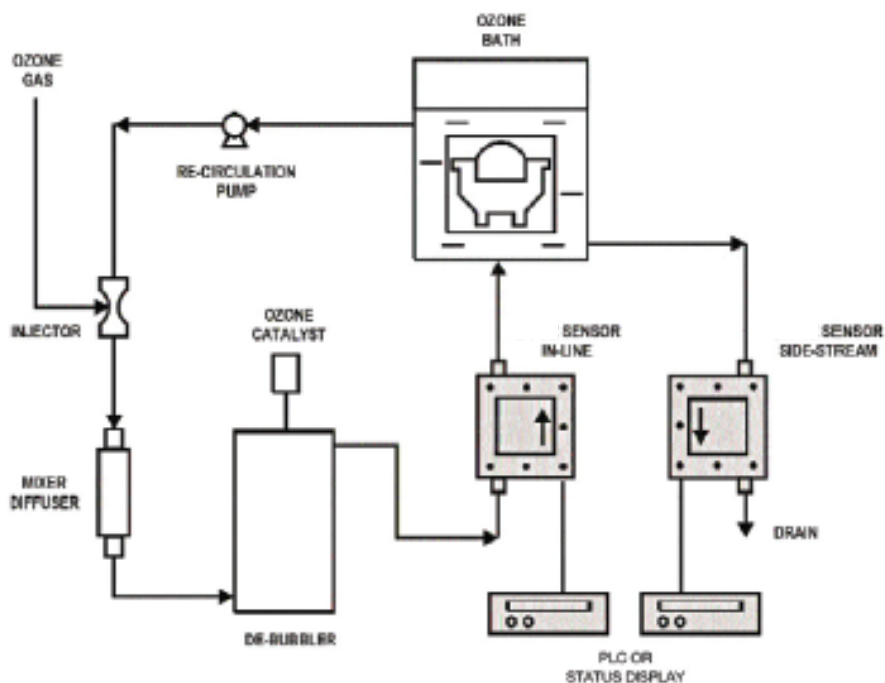

Figure 2-3: Typical Installation, In-Line or Side-Stream

## 2.4. ELECTRICAL CONNECTIONS

Electrical connections are made to the Model 470 using the 15 pin D-Sub connector. The pin-out of the 15-pin connector and typical connections are shown in Figure 2-4.



### CAUTION

If using a TAPI controller, connect **ONLY** to the SCI-552 Controller. **DO NOT** connect the Model 470 to any of the following controllers: SCI-Plus, SCI-Turbo, SCI-Turbo L, SCI-Turbo Mega, SCI-Turbo Mini

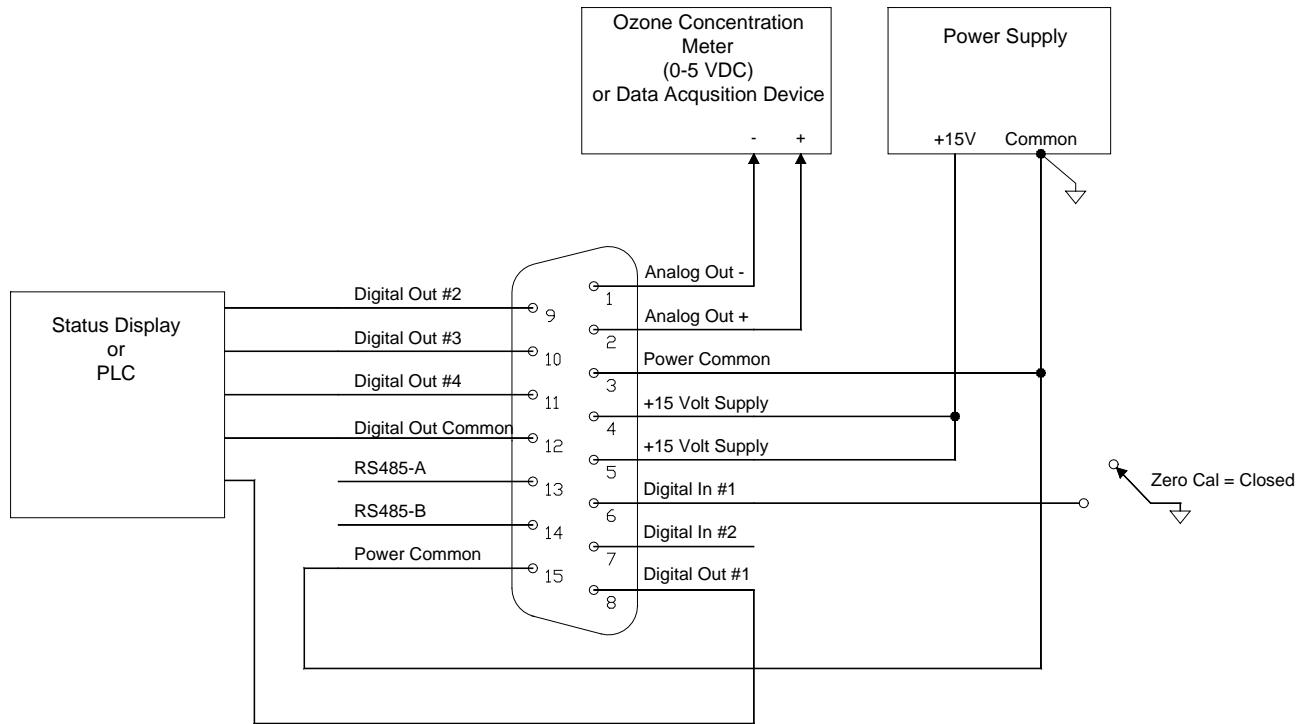

**Figure 2-4: Digital Output Connections**

### 2.4.1. POWER SUPPLY

The Model 470 requires a +15 VDC power source capable of supplying 1.0 A. DC power is connected through the male DB-15 connector. The positive terminal of the power supply should be connected to pins 4 and 5 on the 15-pin connector and the common terminal should be connected to pins 3 and 15.

### 2.4.2. ANALOG OUTPUT

The analog output is a 0-5 volt, or 4-20 mA (Factory-configured), signal representing the ozone concentration measured by the sensor. The output is scaled to the concentration range that the sensor has been set to measure. Check the serial number label on the Model 470 to determine the concentration range.

For best performance, the 0-5 VDC analog output should be connected to a voltmeter or A/D converter with a differential input and a minimum input impedance of 2K $\Omega$ .

The 4-20mA output has a built-in isolated loop power supply, and can drive receiver loads of up to 400 ohms.

### 2.4.3. ZERO CALIBRATION INPUT

The zero calibration input is located on Digital Input #1. To zero the Model 470, Digital Input #1 should be connected to the power common for at least 1 second. This can be accomplished using a Normally Open switch or relay.

### 2.4.4. STATUS OUTPUTS

The Model 470 has four digital status outputs for indicating error status and when operational parameters have moved out of normal limits. These outputs are in the form of opto-isolated open-collector transistors. They can be used to drive status LED's on a display panel or interface to a digital device such as a Programmable Logic Controller (PLC).

Figure 2-5 below shows the most common way of connecting the digital outputs to an external device such as PLC. Note: Most devices, such as PLC's, have internal provision for limiting the current that the input will draw from an external device. When connecting to a unit that does not have this feature, external dropping resistors must be used to limit the current through the transistor output to 50mA or less.

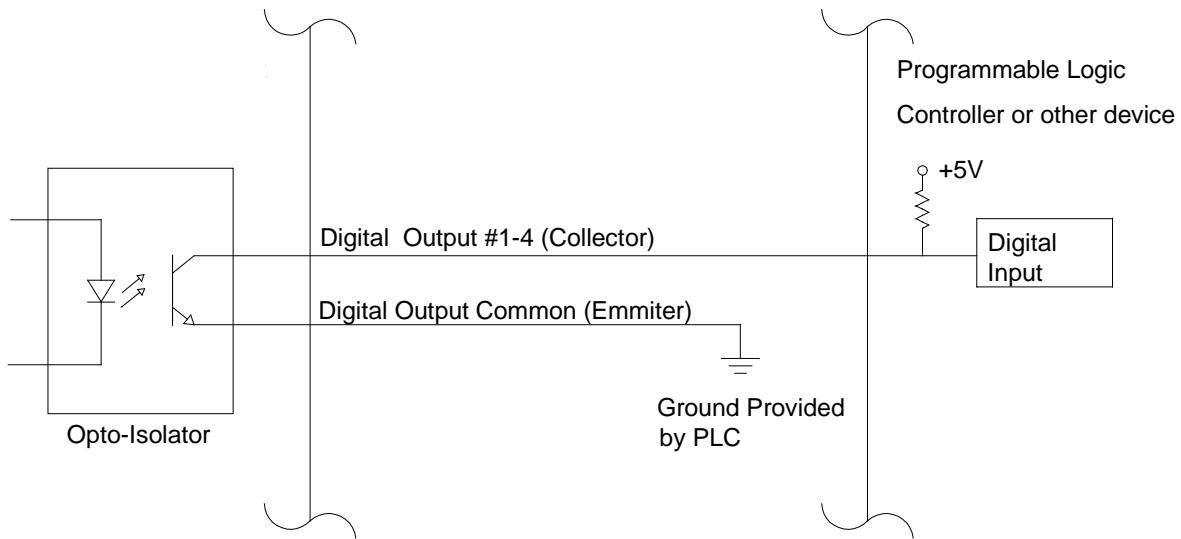

Figure 2-5: Digital Status Outputs

### 2.4.5. RS232/485 INTERFACE

The Model 470 features a bi-directional digital serial interface that can be used for sensor control and data acquisition (Figure 2-1). Please contact Teledyne API for documentation on the use of the RS232/485 interface.

## 3. OPERATION

### 3.1. INITIAL POWER-ON AND WARM-UP

Allow the sensor to warm at least overnight on initial startup or on any “cold” start. This warm-up period should preferably be done while ozone-free fluid is flowing through the sensor. After the warm-up period, zero the sensor (Section 2.4.3) with an ozone-free reference fluid.

It is recommended that the sensor be powered on around the clock to ensure peak performance, minimal zero drift, and maximum system life.

### 3.2. ZEROING THE SENSOR

Due to its innovative sensing technology, the Model 470 is a highly zero-stable instrument, but should be zeroed periodically.

1. Purge the sensor with an ozone-free reference fluid, typically deionized water, to get rid of dissolved ozone inside the optical chamber for about 15 minutes.
2. Start the zeroing process using the zero calibration digital input as described in Section 2.4.3.

## 4. TROUBLESHOOTING

Troubleshooting based on the digital outputs. This section describes the digital outputs (Figure 2-5 and Figure 2-4), Status Outputs #1 thru 4.

**Table 4-1: Status Outputs**

Output #	Name	On State	Off state
1	Sensor O.K.	Normal State	A Channel or B Channel > 2995mV; A Channel < 250mV
2	Invalid Reading	Ozone Concentration Out of Range	Normal State
3	Lamp Low	A Channel Detector < 350mV	Normal State
4	Cell Dirty	A Channel gain factor falls < 0.5	Normal State

### 4.1. STATUS OUTPUT SUMMARY

Table 4-2 summarizes the Status Output descriptions and recommended actions.

- 1 = output is ON
- 0 = output is OFF
- X = output is in either state.

**Table 4-2: Status Output Truth Table**

Sensor OK	Invalid Reading	Lamp Low	Cell Dirty	Actions
1	0	0	0	Normal operation, no action required.
0	X	X	X	Service required.
1	1	X	X	Verify that concentration has not exceeded full scale range of sensor. Calibrate at Zero.
1	X	1	X	Action may not be required immediately; otherwise, service soon.
1	X	X	1	Calibrate at zero. Call for service



## 4.2. STATUS OUTPUT DESCRIPTIONS

### 4.2.1. SENSOR O.K.

The normal state for the Sensor O.K. output is ON. During the warm-up period on start-up this output will stay off until the UV lamp reaches a minimum intensity. If this output remains off after the 15-minute warm-up period, or goes off during normal operation, then the instrument is in need of servicing.

If the Sensor O.K. output turns off AND the Lamp Low output is on, this indicates that the lamp intensity is below the minimum level required for proper operation and is in need of servicing.

If the Sensor O.K. output turns off and the Lamp Low output is also off, then one of the analog voltages in the sensor has exceeded the range of the internal A/D converter. Adjustment by qualified service personnel is required.

### 4.2.2. INVALID READING

The normal state for the Invalid Reading output is OFF. If this output turns on, this indicates that the instrument is still operational, but a system fault or calibration fault exists that may make the current ozone reading invalid. The Invalid Reading output is turned on for either of the following conditions:

- When the measured concentration has exceeded the full-scale concentration range of the sensor. Check the serial number tag for the full-scale concentration range.
- The sensor is indicating an excessive negative reading.

### 4.2.3. LAMP LOW

The normal state for the Lamp Low output is OFF. If this output turns on, this indicates that the UV lamp intensity of A Channel has dropped below 350mV.

If the Lamp Low output turns ON and the Sensor O.K. output is ON, this indicates that the lamp intensity is still adequate for measurement, but service may be required soon.

If the Lamp Low output turns ON and the Sensor O.K. output is OFF, this indicates a failure condition and accurate measurement is no longer possible.

### 4.2.4. CELL DIRTY

The normal state for the Cell Dirty output is OFF. If this output turns on, then the A Channel gain factor has fallen to  $< 0.5$ . This value is calculated when the zero calibration is performed.

When this output is on, it indicates a loss of optical transmission through the windows in the absorption cell or a calibration fault.

## 5. MAINTENANCE

The only maintenance typically required is replacing the UV lamp once every 2-3 years.

### 5.1. TECHNICAL ASSISTANCE

If needed, please contact our Technical Support Department for technical assistance.

**TELEDYNE API, TECHNICAL SUPPORT,  
9480 CARROLL PARK DRIVE  
SAN DIEGO, CALIFORNIA 92121-5201  
USA**

**Toll-free Phone: 800-324-5190  
Phone: 858-657-9800  
Fax: 858-657-9816  
Email: [sda\\_techsupport@teledyne.com](mailto:sda_techsupport@teledyne.com)**